

A Hybrid Railway Power Conditioner for Traction Power Supply system

NingYi Dai, KengWeng Lao, ManChung Wong
Electrical and computer engineering department
University of Macau
Macau, P.R. China
nydai@umac.mo

Abstract— Co-phase traction power supply system was proposed for supplying the long-distance electrified railway without neutral sections. However, a railway power compensator (RPC) needs to be installed in each substation together with the traction transformer for improving the power quality. The RPC is mainly constructed by a back-to-back converter, which can reduce the unbalance currents by active power transfer and compensate reactive current and harmonics at the same time. A hybrid railway power conditioner (HRPC) is proposed for the co-phase traction power supply system in this paper. The HRPC uses a LC coupling branch between the converter and the traction supply. It is able to operate at a lower converter rating for achieving the same performance compared with conventional RPC. As a result, the initial cost and operational losses are reduced. The design of the LC coupling impedance and the DC bus voltage of the HRPC is focused on in this paper based on the mathematical models. The control system is implemented. Simulation results are provided and comparison with RPC is also given. Experimental results are provided to show the validity of the HRPC.

I. INTRODUCTION

The 25kV AC system has been adopted in the long-distance electrified railway. The single-phase traction transformer is widely used in traction substation due to its low cost and simple structure [1]-[3]. The single-phase transform is connected to two phases of the transmission line at the grid side. This results in an imbalance on the three-phase supply which may affect other customers. One of the solutions is to choose the feeding phases of the traction substations in turn, as illustrated in Fig.1[4][5].

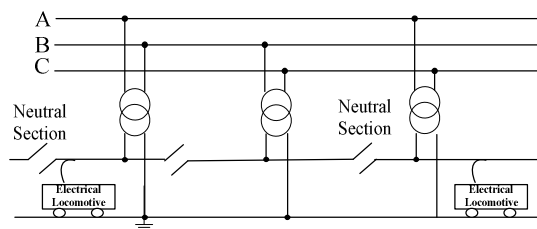

Figure 1. Traditional traction power supply system

However, neutral section (NS) needs to be inserted for separating the supply system to electrically isolated sections with length of 20km to 30km [6]. The length of the NS varies from several hundred meters to more than 1km. The fact that electric locomotive needs to slide across the NS without power supply, affects its speed and may make the passengers feel uncomfortable. Expensive automatic switches and their controllers are required for switching the power supply of the locomotive at each neutral section [7][8]. In addition, the traction power supply system still suffers from the system unbalance, since loads cannot be distributed evenly among sections [9].

Co-phase traction power supply system is proposed [10]-[12], which can supply the traction loads without neutral sections, as shown in Fig.2. The number of NS is cut down by half in the co-phase power supply system. The remained NSs are replaced by section separator, for which the requirement of insulation is reduced since the terminal voltage difference between the two neighboring sections is much smaller. In the substation of the co-phase power supply system, a railway power conditioner (RPC) is used together with the balance feeding transformer to feed the single-phase traction loads [11]-[14]. The primary side of the balance feeding transformer is connected to the three-phase power grid. It provides two single-phase outputs at the secondary side, and one of them directly supplies the traction loads. The other phase supplies the loads indirectly via the RPC. By controlling the RPC, the feeding transformer draw three-phase balanced currents from the grid. In addition, the harmonic and reactive power of the traction loads can be compensated by the RPC.

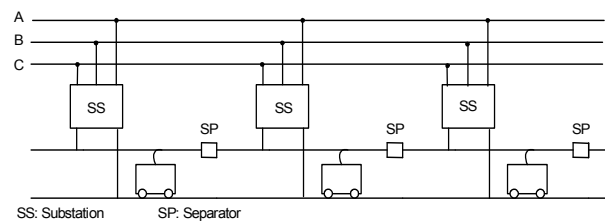

Figure 2. Co-phase traction power supply system

The research is funded by Science and Technology Development Fund, Macao SAR Government and University of Macau.

The single-phase back-to-back converter is adopted in the RPC to achieve the power conditioning [11]-[14]. However, the rating of the power converter in the RPC for the co-phase power supply system could be larger than 10MVA in order to achieve the required power conditioning. The high initial cost of the power converter is one of the main obstacles for promoting the co-phase power supply system.

The LC coupling impedance can reduce the DC bus voltage of the power converter when it is used in a hybrid filter for compensating reactive current and harmonics [15][16]. In this paper, the LC coupling impedance is adopted in one phase of the RPC and a hybrid railway power conditioner (HRPC) is proposed. The proposed configuration of one substation of the co-phase power supply system is shown in Fig. 3, in which a V/V transformer is used as the balance feeding transformer. Other balance feeding transformers are also applicable, but the current relationships on the primary side and secondary side are different due to transformer winding connections [9][17].

The HRPC can achieve active power balancing, reactive power compensation and harmonic filtering in the co-phase power supply system. However, the rating of the back-to-back converter in the HRPC can be lower than that of a RPC for achieving the same goal. Since the power converter in railway power compensator ranges from several MVA to more than ten MVA, a large amount of money could be saved. In section II the basic operational principle of the HRPC is introduced. The design and implementation of the HRPC is provided in section III. Simulation results are given in section IV and experimental results are given in section V. Finally, a conclusion is provided in section VI.

II. BASIC OPERATIONAL PRINCIPLE OF THE HRPC

In the co-phase power supply system, the traction loads are supplied by one phase of the V/V traction transformer, which is denoted as α -phase in this paper. The supply voltage for the traction loads is expressed in (1), and load current is given in (2).

$$v_{\alpha} = v_{ac} = \sqrt{2}V_{ac} \sin(\omega t - 30^{\circ}), \quad (1)$$

$$i_L = \sqrt{2}I_{L1p} \sin(\omega t - 30^{\circ}) - \sqrt{2}I_{L1q} \cos(\omega t - 30^{\circ}) + i_{Lh} \quad (2)$$

where $I_{L1p} = I_{L1} \cos \varphi_1$, $I_{L1q} = I_{L1} \sin \varphi_1$ and φ_1 is the phase angle between the fundamental frequency supply voltage and the load current. i_{Lh} denotes the harmonic component of the load currents. The other phase at the secondary side of the V/V transformer is denoted as β -phase and its output voltage is given in (3).

$$v_{\beta} = v_{bc} = \sqrt{2}V_{bc} \sin(\omega t - 90^{\circ}) \quad (3)$$

The fundamental frequency model of the railway power supply system is first analyzed. In this model, the active power and the fundamental frequency reactive power of the traction loads are the main concern.

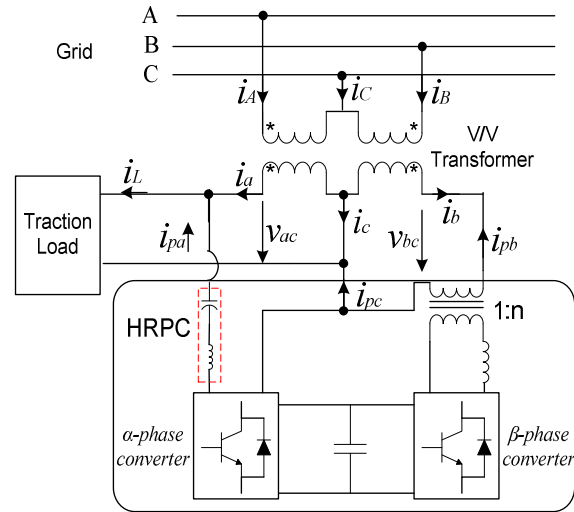

Figure 3. Structure of the proposed co-phase power supply system with HRPC

When there is no railway power conditioner in the supply system, the vector diagram is shown in Fig.4. The current at the secondary side of the V/V transformer is given in (4). The three-phase power system supplies a single phase load and large unbalance exists in the phase currents. The harmonics and reactive component in the load currents also affect the railway power supply system.

$$\begin{bmatrix} i_a \\ i_b \\ i_c \end{bmatrix} = \begin{bmatrix} i_L \\ 0 \\ -i_L \end{bmatrix} \quad (4)$$

As shown in Fig.3, a hybrid railway power conditioner is connected to the supply system. The α -phase converter of the HRPC is connected in parallel with the traction loads via a LC coupling branch and the β -phase converter is connected to the β -phase of the V/V transformer. The output currents of the HRPC at the α -phase and the β -phase are denoted as i_{pa} and i_{pb} respectively. The corresponding vector diagram is shown in Fig.5. The output currents of the HPQC are expressed by (5).

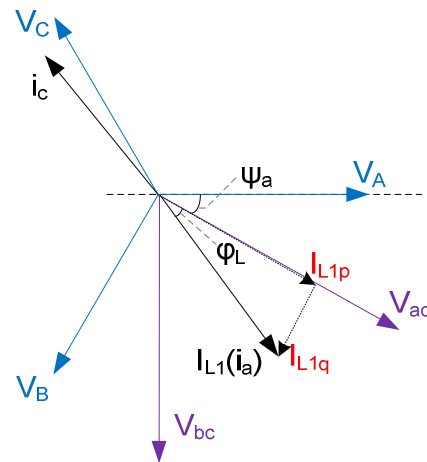

Figure 4. Vector diagram of the railway supply system without RPC

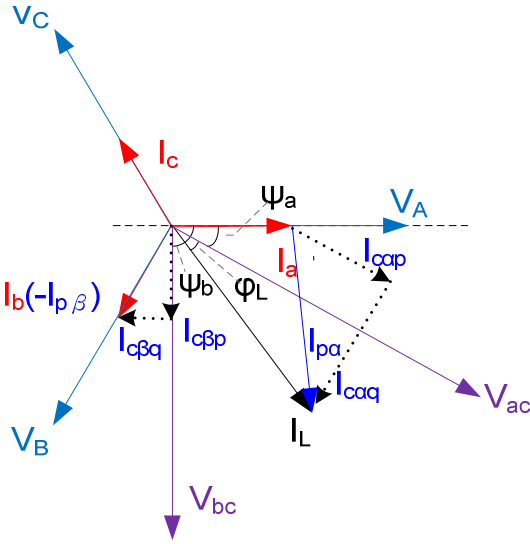

Figure 5. Vector diagram of the railway power supply system with RPC

$$\begin{bmatrix} i_{pa} \\ i_{pb} \\ i_{pc} \end{bmatrix} = \begin{bmatrix} i_L - i_a \\ -i_b \\ -i_L - i_c \end{bmatrix} \quad (5)$$

The HRPC is designed to balance the three-phase currents at the grid side and compensate load current harmonics and reactive current. In order to achieve these goals, the compensating current of the HRPC is deduced, which has been explained in detail in [18]. The required compensating currents of the HRPC are given in (6).

$$\begin{bmatrix} i_{pa} \\ i_{pb} \\ i_{pc} \end{bmatrix} = \begin{bmatrix} \frac{1}{2}\sqrt{2}I_{L1p} \sin(\omega t - 30^\circ) - (\frac{\sqrt{3}}{6}I_{L1p} + I_{L1q})\sqrt{2} \cos(\omega t - 30^\circ) + i_{Lh} \\ -\frac{1}{2}\sqrt{2}I_{L1p} \sin(\omega t - 90^\circ) + \frac{\sqrt{3}}{6}\sqrt{2}I_{L1p} \cos(\omega t - 90^\circ) \\ -i_{pa} - i_{pb} \end{bmatrix} \quad (6)$$

According to (6), the output power of the α -phase and the β -phase converter of the HRPC can be calculated by multiplying the output current with the supply voltage at the coupling points. The results are given in (7).

$$\begin{bmatrix} p_{pa} \\ q_{pa} \\ p_{pb} \\ q_{pb} \end{bmatrix} = \begin{bmatrix} 0.5 * \bar{p}_L + \tilde{p}_L \\ q_L + \frac{\sqrt{3}}{6} * \bar{p}_L \\ -0.5 * \bar{p}_L \\ -\frac{\sqrt{3}}{6} * \bar{p}_L \end{bmatrix} \quad (7)$$

It is clear that both active power and reactive power needs to be controlled by the back-to-back converter of the HRPC. The HRPC absorbs active power from the β -phase and injects the active power to supply the traction loads at the α -phase. It also provides reactive power and harmonic power to compensate the traction loads. The reactive power absorbed at the β -phase is for achieving a unity power factor at the primary side of the traction transformer.

III. DESIGN AND IMPLEMENTATION OF THE HRPC

The HRPC is designed to provide the required power conditioning at a reduced dc link voltage. The design of the HRPC is first discussed in this section, and the block diagram of its control system is then presented.

A. System Parameters Design

The α -phase and the β -phase converter of the HRPC share the same dc bus. As shown in Fig.3, a coupling transformer is connected at the β -phase, providing more flexibility for the output voltage at the β -phase. Hence, the dc bus voltage of the HRPC is determined by the required output voltage at the α -phase. The fundamental frequency output voltage of the α -phase converter is expressed as:

$$\vec{V}_{inv\alpha 1} = \vec{V}_{ac} + \vec{V}_{LC} = \vec{V}_{ac} - jX_{LC} \cdot \vec{i}_{pa1} \quad (8)$$

where \vec{i}_{pa1} is the fundamental frequency compensating current and \vec{V}_{LC} is the voltage across the LC branch. In the HRPC, the coupling capacitor is designed for reactive power compensation and the coupling inductor is used for reducing the current ripple. The impedance X_{LC} of the LC branch is capacitive and is given in (9), where ω is the fundamental frequency of the supply system.

$$X_{LC} = \frac{1}{\omega C} - \omega L \quad (9)$$

As a result, the \vec{V}_{LC} is obtained by rotating \vec{i}_{pa1} 90 degrees clockwise. The corresponding vector diagram is shown in Fig.6. The phase angle of \vec{i}_{pa1} is denoted as θ and is calculated by (10), in which $\tan\phi_1 = I_{L1p}/I_{L1q}$ and it is determined by the traction load power factor.

$$\theta = \tan^{-1}\left(\frac{\frac{1}{2\sqrt{3}}I_{L1p} + I_{L1q}}{\frac{1}{2}I_{L1p}}\right) = \tan^{-1}\left(\frac{1}{\sqrt{3}} + 2 \tan\phi_1\right) \quad (10)$$

If the amplitude of the compensating current changes, the voltage vector \vec{V}_{LC} varies along Line L in Fig. 6.

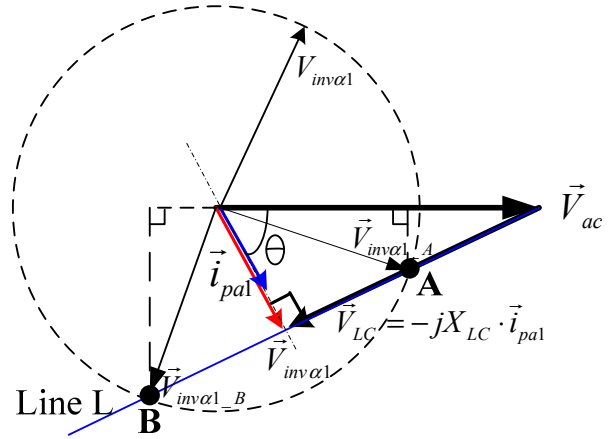

Figure 6. Vector diagram for α -phase converter

The voltage rating of the α -phase converter needs to cover a certain load current variation range. It is assumed the fundamental frequency voltage rating of the α -phase converter is $V_{inv\alpha 1}$ and the output range is bounded by the dashed circle in Fig.6. The compensating current range is limited between \vec{i}_{pa1_A} and \vec{i}_{pa1_B} , where points A and B are the intersections between the circle and Line L. If I_{pa1_A} and I_{pa1_B} are the amplitude of the compensating currents at points A and B, the corresponding output voltage of the α -phase converter is given in (11) and (12).

$$V_{inv\alpha 1_A}^2 = (V_{ac} - I_{pa1_A} X_{LC} \cdot \sin\theta)^2 + (I_{pa1_A} X_{LC} \cdot \cos\theta)^2 \quad (11)$$

$$V_{inv\alpha 1_B}^2 = (I_{pa1_B} X_{LC} \cdot \sin\theta - V_{ac})^2 + (I_{pa1_B} X_{LC} \cdot \cos\theta)^2 \quad (12)$$

Assuming all the other factors are kept as constant value, the variation of converter output voltage with coupling impedance X_{LC} is shown in Fig.7. In order to cover the required compensation range, the converter voltage rating should satisfy both $V_{inv\alpha 1_A}$ and $V_{inv\beta 1_B}$. The HRPC is designed to achieve the compensation range with the minimum converter voltage rating, and the minimum voltage is the one at the cross points in Fig. 7. As a result, the coupling impedance at this point is selected and is calculated based on the assumption $V_{inv\alpha 1_A} = V_{inv\beta 1_B}$. By subtracting (12) from (11), the coupling impedance value is deduced and given in (13).

$$X_{LC} = \frac{V_{ac} \sin\theta}{(I_{pa1_A} + I_{pa1_B})/2} \quad (13)$$

Similar to other application of LC coupling branch in a parallel connected power filters, the LC branch of the HRPC is also designed to resonant at a certain harmonic frequency for suppressing the harmonics. It is assume the LC branch resonant at n th harmonic, (14) is deduced. Combing (9), (13) and (14), and value of each coupling impedance can be obtained.

$$\frac{1}{n\omega C} = n\omega L \quad (14)$$

Eq. (13) also indicates that only one crossing point exists, as shown in Fig. 7. By substituting X_{LC} to either (11) or (12), the same results for the converter voltage are obtained and one expression is given in (14).

$$V_{inv\alpha 1} = \sqrt{1 - \frac{4I_{pa1_A} \sin^2\theta}{I_{pa1_A} + I_{pa1_B}} + \left(\frac{2I_{pa1_A} \sin\theta}{I_{pa1_A} + I_{pa1_B}}\right)^2} \cdot V_{ac} \quad (14)$$

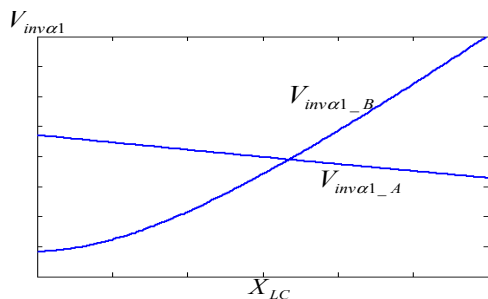

Figure 7. Variation of converter output voltage with coupling impedance

The DC bus voltage could be estimated according to the peak value of converter output voltage. For example, it is assumed two 10MVA 110kV/27.5kV transformers are used to construct a V/V transformer for the co-phase power supply system. The displacement power factor of the traction loads is 0.8. The phase angle θ equals 64.33 degree. The required compensating current is set in the range of 100A to 450A. According to (11), the converter voltage rating equals 19.8 kV and the corresponding dc bus voltage of the HRPC is set as 28 kV. However, the dc bus voltage for RPC should be 40kV.

The previous discussion only analyzes the required voltage rating of the α -phase converter, when fundamental frequency compensating currents are generated. When the harmonic compensation is also considered, the RMS value of the required output voltage of the inverter could be estimated by (15), where $V_{inv\alpha h}$ is the required voltage for harmonic compensation.

$$V_{inv\alpha} = \sqrt{V_{inv\alpha 1}^2 + V_{inv\alpha h}^2} \quad (15)$$

The detailed deduction of (15) can be found in previous work [18]. According to analyses in [18], the voltage rating of the β -phase converter is selected to be equal to supply voltage, i.e. V_{β} . Consequently, the ratio of turns of the isolation coupling transformer at the β -phase should be smaller than $V_{inv\alpha}/V_{\beta}$.

B. System Implementation

The configuration of the HRPC is shown in Fig.8. A single-phase full-bridge back-to-back converter is adopted for illustrating the operational principle of the proposed system. Practically, multi-level converter needs to be applied if the α -phase converter is connected to the supply without coupling transformer [19][20]. Fig. 9 illustrates the control diagram of the proposed HRPC. In order to calculate the reference currents in (6), the instantaneous power method is used. The instantaneous active and reactive power is calculated by (16), in which $v_{\alpha d}$ and i_{Ld} are 90 degree delay of the system voltage and load current, respectively. LPF in Fig.8 is a low pass filter for getting the dc component of the load active power.

$$\begin{bmatrix} p \\ q \end{bmatrix} = \begin{bmatrix} v_{\alpha} \cdot i_L + v_{\alpha d} \cdot i_{Ld} \\ v_{\alpha d} \cdot i_L - v_{\alpha} \cdot i_{Ld} \end{bmatrix} \quad (16)$$

The reference currents at each phase is calculated by (17) and (18) according to the required output power of the converter. Except those included in (7), the power for regulating the dc link voltage is also added in the output power at the β -phase. Similarly, $v_{\beta d}$ is 90 degree delay of system voltage v_{β} .

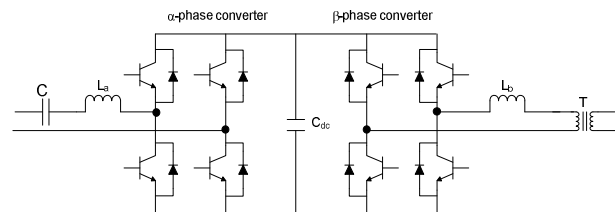

Figure 8. Configure of the HRPC.

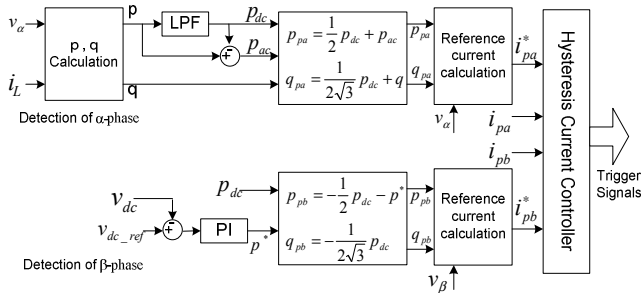

Figure 9. Control system of the HRPC

$$i_{pa}^* = \frac{1}{v_{\alpha}^2 + v_{\alpha d}^2} \begin{bmatrix} p_{pa} \\ q_{pa} \end{bmatrix} \quad (17)$$

$$i_{pb}^* = \frac{1}{v_{\beta}^2 + v_{\beta d}^2} \begin{bmatrix} p_{pb} \\ q_{pb} \end{bmatrix} \quad (18)$$

IV. SIMULATION RESULTS

Simulations are done by using PSCAD/EMTDC. When there is no HRPC in the traction power supply system, the currents at the primary side and the secondary side of the V/V transformer are shown in Fig.10. The current at the primary side is just the currents drawn from the three-phase power grid. It can be found current unbalance exists due to a single-phase load is supplied.

The configuration of the HRPC in simulation is shown in Fig.8. The parameters of the HRPC are listed in Table I. The dc link voltage of the HRPC is set to 28kV. After the HRPC operates, the currents at the primary side and the secondary side of the V/V transformer are shown in Fig.11. By removing capacitor C at the α -phase of the HRPC, it becomes a conventional RPC, which needs a dc link voltage of 40V to achieve the same performance. The simulation results of the RPC are given in Fig.12.

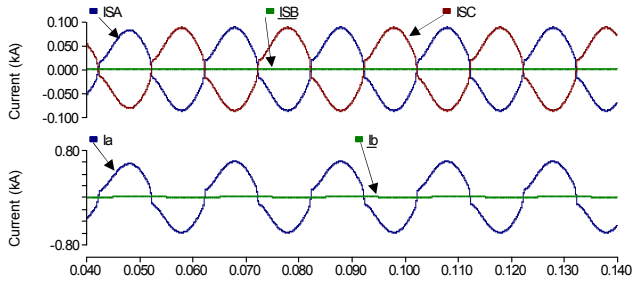

Figure 10. Co-phase power supply system without HRPC (a) Currents at the grid side (b) Currents at the secondary sides of the V/V transformer

TABLE I. PARAMETERS IN SIMULATION

No.	Items	Description
1	V/V transformer	110kV/27.5kV
2	α -phase Coupling Inductor L_a	7.6 mH
3	α -phase Coupling Capacitor C	60 μ F
4	Capacitor C_{dc}	10000 μ F
5	β -phase Coupling Inductor L_b	5mH
6	β -phase Coupling Transformer of HRPC	27.5kV/13.75kV
6	β -phase Coupling Transformer of RPC	27.5kV/13.75kV

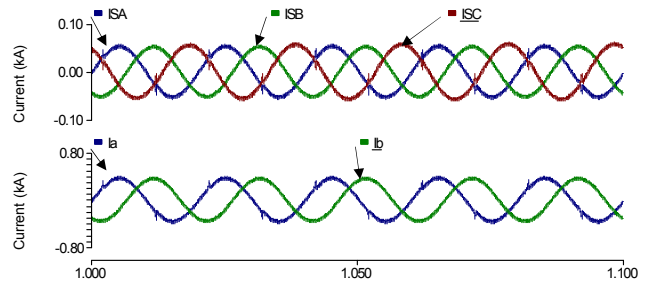

Figure 11. Co-phase power supply system with HRPC (a) Currents at the grid side (b) Currents at the secondary sides of the V/V transformer

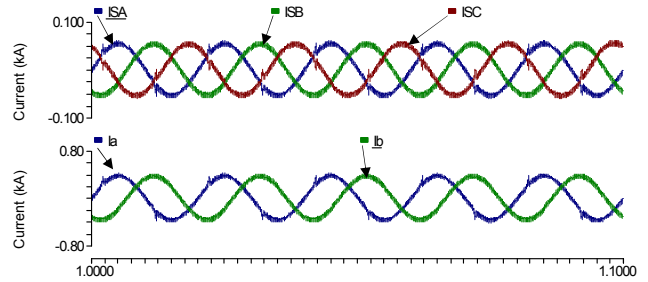

Figure 12. Co-phase power supply system with RPC (a) Currents at the grid side (b) Currents at the secondary sides of the V/V transformer

The parameters for compensation performance comparisons are given in Table II, in which the current unbalance is calculated by (19). Results indicate that the system unbalance, reactive power and harmonics are simultaneously compensated by the HRPC and RPC, but the dc voltage of the HRPC is lower, which reduced the initial cost and operational losses of the power conditioner.

$$\text{Current unbalance factor} = \frac{|I^-|}{|I^+|} \times 100\% \quad (19)$$

The compensation range is also tested. Traction loads are modeled as RL loads with power factor of 0.8 in simulation. The harmonics currents are not included, as compensation range is difficult to evaluate when harmonic compensation is also considered. It is assumed the full load capacity of the traction loads is 15 MVA, the required compensating currents at the α -phase is about 500A. The simulation results are given in Fig.13. Results indicate that the HRPC nearly fully compensated the unbalance currents in the designed operational range, i.e. 100A to 450A. When the dc voltage of the RPC is also set to 28kV, its performance is also shown in Fig.13. Results indicate that the HPQC is better than the conventional RPC, when the dc link voltage is reduced to about 70% of the original value.

TABLE II. COMPENSATION PERFORMANCE COMPARISONS

Currents at the grid side	Before Compensation			With RPC (Vdc=40 kV)			With HPQC (Vdc=28 kV)		
	A	B	C	A	B	C	A	B	C
rms (A)	62.9	0	62.9	38.0	36.9	40.2	37.2	36.3	38.7
Power factor	0.7	---	0.96	1.0	1.0	1.0	1.0	1.0	1.0
THD (%)	10.1	---	10.1	4.82	1.40	5.02	3.17	1.04	3.25
Current unbalance(%)	99			4.25			3.46		

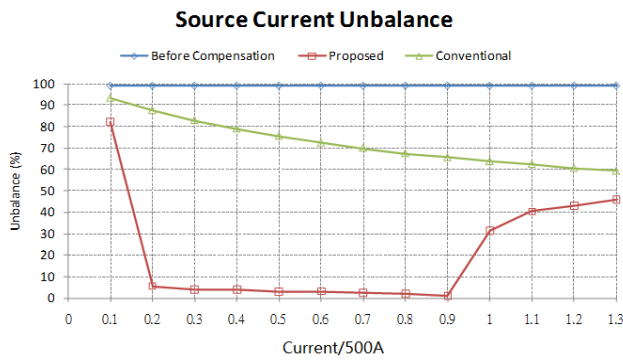

Figure 13. Comparisons between compensation performance using HRPC and RPC.

V. EXPERIMENTAL RESULTS

The System configuration of the co-phase power supply system is shown in Fig. 3 and the structure of the HRPC is shown in Fig.8. Two 5kVA single-phase transformers are used to construct a V/V transformer. A small capacity prototype was built. The three-phase currents at the grid side without and with the HRPC are shown in Fig.14. Results indicate that current unbalance, reactive current and current harmonics are compensated simultaneously.

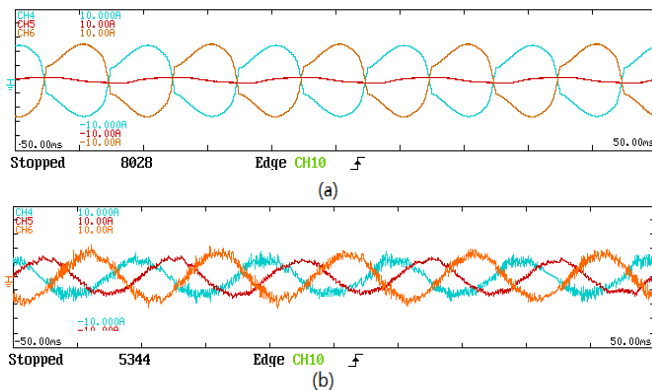

Figure 14. Three-phase currents at the grid side (a) Co-phase power supply system without HRPC (b) Co-phase power supply system with HRPC

VI. CONCLUSIONS

In this paper, a HRPC is proposed for the co-phase power supply system for electrical railway power supply system. The HRPC operates at a lower DC bus voltage compared to RPC. As a result, the initial cost and operational losses of the railway power conditioner could be reduced. Simulation and experimental results show the HRPC could compensate the unbalance current, reactive current and current harmonics simultaneously.

REFERENCES

[1] Pee-Chin Tan, Poh Chiang Loh, Donald Grahame Holmes, "Optimal impedance termination of 25-kV electrified railway systems for improved power quality," *IEEE Trans. Power Delivery*, Vol.20, No.2, pp. 1703-1710, Apr. 2005.
 [2] Z. Han, Y. Zhang, S. Liu and S. Gao, "Modeling and simulation for traction power supply system of high-speed railway", in *Proc. of Power and Energy Engineering Conf. (APPEEC)*, 2011, pp. 1-4

[3] T. Kneschke, "Voltage flicker calculations for single-phase AC railroad electrification systems", *Proc. Of the 2003 IEEE/ASME Rail Conf.*, 2003, pp. 161-170.
 [4] L.Battistelli, D. Lauria and P. Vernillo, "Control strategy of advanced 25kV-50Hz electrified railway systems", *IEE Proc.-Electr. Power Appl.*, Vol. 148, No.1, pp. 97-104, Jan. 2001
 [5] S. T. Senini, P. J. Wolfs, "Novel topology for correction of unbalanced load in single phase electric traction systems," in *PESC Rec. IEEE Annu. Power Electronics Specialists Conf.*, vol. 3, Cairns, Australia, June 2002, pp. 1208-1212.
 [6] Zhengqing Han, Zhihui Dong, Shibin Gao, Zhiqian Bo, "Protection scheme for out-of-phase short-circuit fault of traction feeding network", *Proc. 11th Conf. on Developments in Power System Protection (DPSP)*, 2012, pp.1-4.
 [7] Han, Z., Liu, S., and Gao, S.: 'An Automatic System for China High-speed Multiple Unit Train Running Through Neutral Section with Electric Load.' *Proc. Asia-Pacific Power and Energy Engineering Conference (APPEEC)*, Chengdu, P.R. China, March 2010, pp.1-3.
 [8] Chen, D., Pan, M., Tian, W., and Yang, W.: 'Automatic neutral section passing control device based on image recognition for electric locomotives.' *Proc. Int. Conf. Imaging systems and Techniques (IST)*, Thessaloniki, Greece, July 2010, pp. 385-388.
 [9] Gao Lin, Xu Yonghai and Xiao Xiangnin, *et al.*, "Analysis of adverse effects on the public power grid brought by traction power-supply system", in *Proc. 2008 IEEE Electrical Power & Energy Conf.*, 2008, pp.1-7.
 [10] Minwu Chen, Qunzhan Li and Guang Wei, "Optimized design and performance evaluation of new cophase traction power supply system", in *Power and Energy Engineering Conference, 2009. APPEEC 2009, Asia-Pacific*, 2009, pp.1-6.
 [11] Z. Shu, L. Xie and Q. Li, "Single-phase back-to-back converter for active power balancing, reactive power compensation and harmonic filtering in traction power system", *IEEE Trans. Power Electronics*, Vol. 26, Issue 2, pp. 334-343, 2011.
 [12] Fulin Zhou, Qunzhan Li, Daqiang Qiu, "Co-phase traction power system based on balanced transformer and hybrid compensation", *Proc. Asia-pacific power and energy engineering conference (APPEEC)*, 2010, pp.1-4.
 [13] An Luo; Chuanping Wu; Shen, J.; Zhikang Shuai; Fujun Ma; "Railway Static Power Conditioners for High-speed Train Traction Power Supply Systems Using Three-phase V/V Transformers", *IEEE Trans. Power Electronics*, vol. 26, issue 10, pp. 2844-2856, Oct. 2011.
 [14] Chuangping Wu, An Luo, J. Shen, Fu Jun Ma and Shuangjian Peng, "A negative sequence compensation method based on a two-phase three-wire converter for a high-speed railway traction power supply system," *IEEE Trans. Power Electro.*, Vol. 27, No.2, pp. 706-717, 2012.
 [15] H. Akagi, T. Hatada, "Voltage balancing control for a three-level diode-clamped converter in a medium-voltage transformerless hybrid active filter", *IEEE Trans. Power Electro.*, Vol.24, Issue 3, pp. 571-579, 2009.
 [16] Chi-Seng Lam, Wai-Hei Choi, Man-Chung Wong, Ying-Duo Han, "Adaptive dc-link voltage controlled hybrid active power filters for reactive power compensation", *IEEE Transactions on Power Electronics*, vol. 27, no. 4, Apr. 2012, pp. 1758 - 1772.
 [17] Chenxi Dai, Yuanyuan Sun, "Investigation of the Imbalance Current Compensation for Transformers Used in Electric Railways", in *Power and Energy Engineering Conference (APPEEC), 2010 Asia-Pacific*, pp.1-4, 2010.
 [18] N.Y. Dai, K.W. Lao, M. C. Wong, C.K. Wong, "Hybrid power quality conditioner for co-phase power supply system in electrified railway", *IET Power Electronics*, in press.
 [19] Wei, Y., 'Research on control of comprehensive compensation for traction substations based on the STATCOM technology.' Ph.D thesis, Tsinghua University, 2009.
 [20] Tan, P.C., Loh, P.C., and Holmes, D. G.: 'A robust multilevel hybrid compensation system for 25-kV electrified railway applications.' *IEEE Trans. Power Electro.*, 2004, 19, (4), pp. 1043-1052.